

# Mathématiques

**Exercice 1 :** Trace le symétrique de chaque figure.

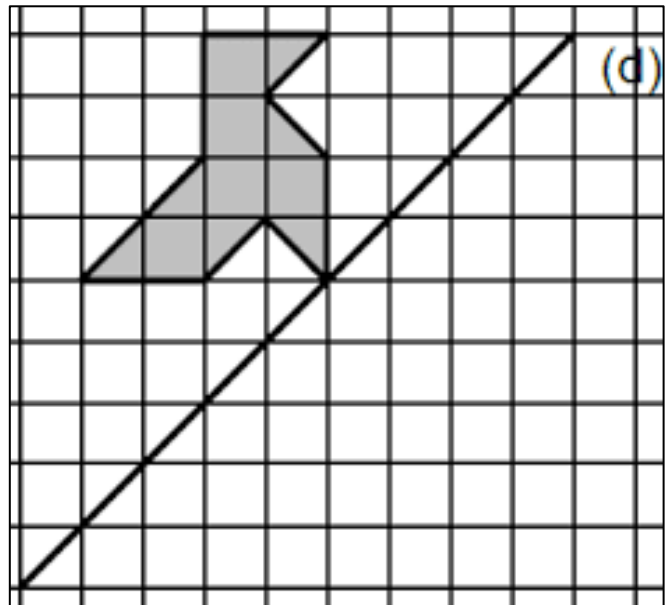

**Exercice 2 :** Trace le symétrique de chaque figure.

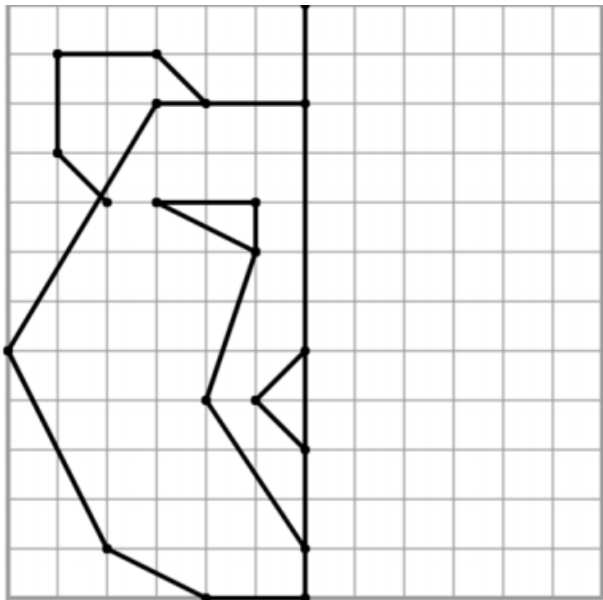
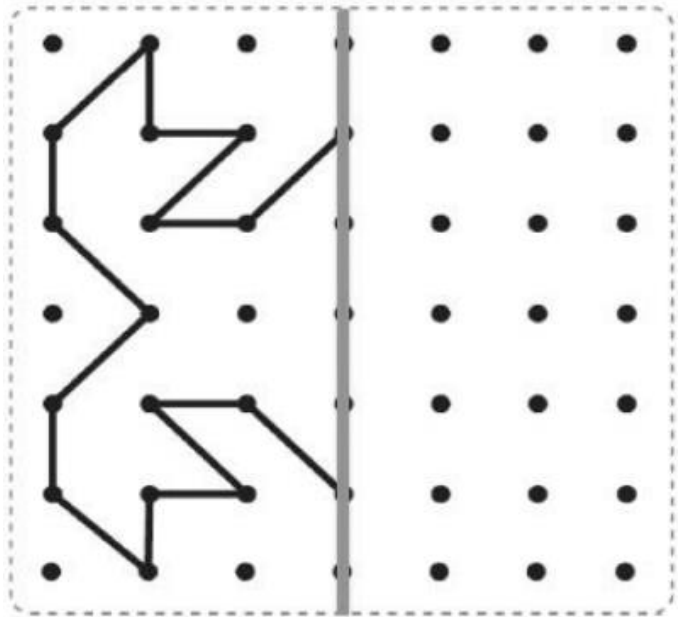
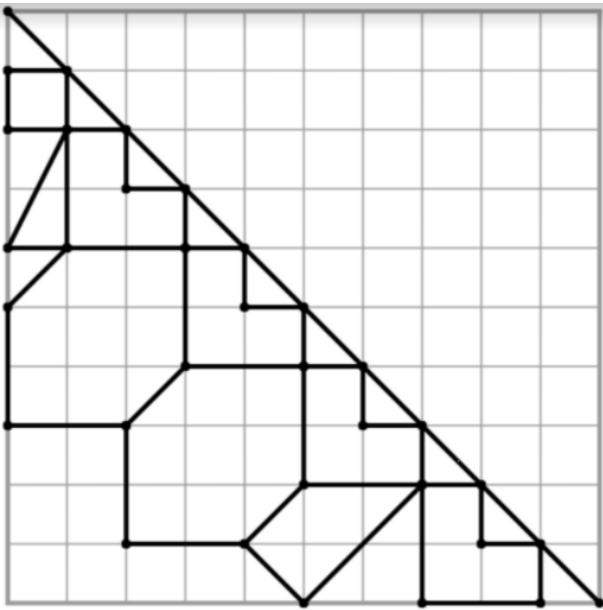
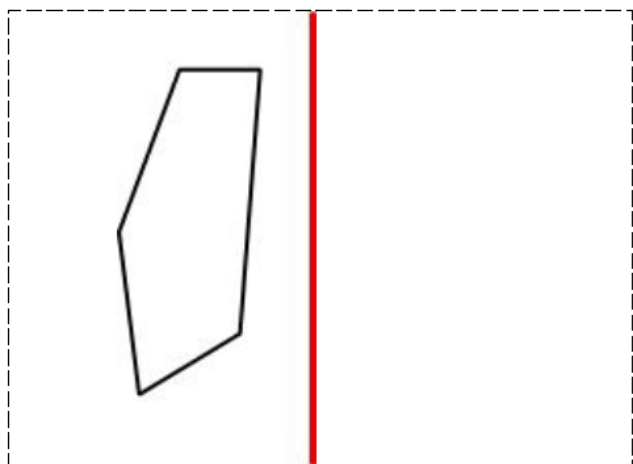
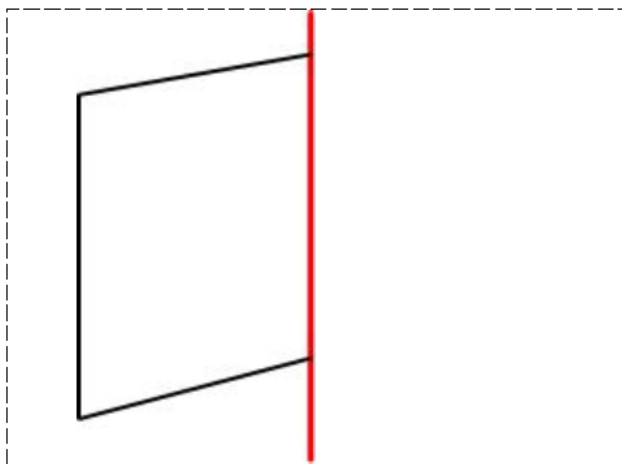

**Exercice 3 (facultatif) : Trace le symétrique de cette figure et colorie-la.**

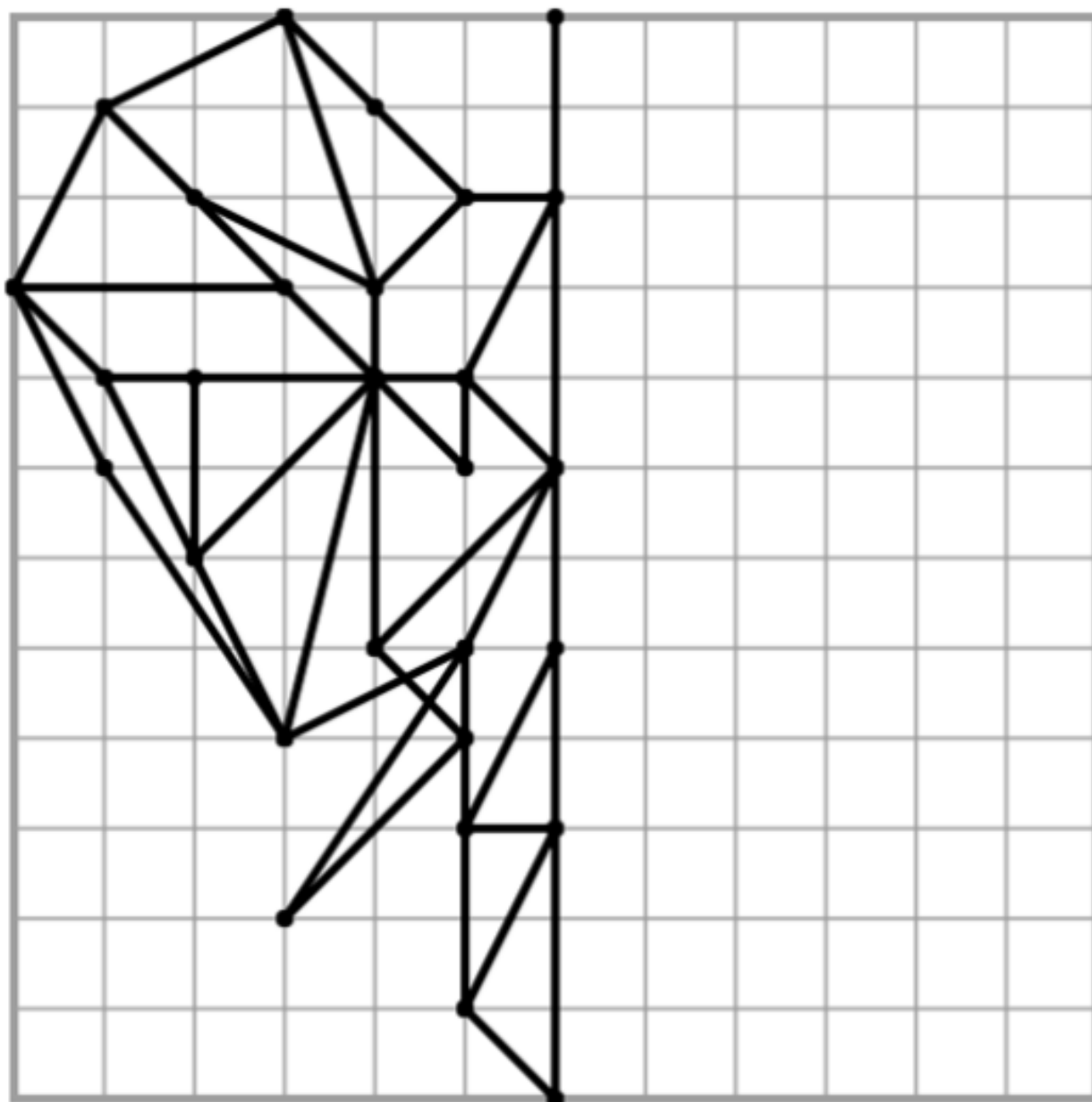

**Exercice 4 : Reproduis cette figure sur une feuille blanche.**

Le diamètre du cercle est égal à 10 cm.

